

Multimode Fiber Characterization Encircled Flux & Launch Condition Considerations

Introduction

Current communication data rates in local networks range from 10/100 Mbps for Ethernet to 1 Gbps in fiber distributed data interfaces (FDDI) or Gigabit Ethernet networks. The increasing demand for Internet Protocol (IP)-based services such as voice, video, and data commands higher speed and larger bandwidth and pushes 10 Gigabit Ethernet in enterprise networks.

In that context, the optical loss budget of multimode cable requires accurate measurement and repeatability, especially when it tends to reach a threshold that ensures the required bandwidth.

Measurements of loss and bandwidth in multimode fibers highly depend upon the launch conditions of the light source used for the measurement. New standards give some guidance to test equipment manufacturers in order to make the optical loss budget measurement repeatable, regardless of the test equipment used.

This document will explain launch conditions in multimode fibers and their impact on the optical loss measurements. The second part is dedicated to the related industry standard and its effect on optical test equipment.

Multimode Fiber

Multimode fibers have a much larger core than single-mode (50, 62.5 mm or even higher), allowing light transmission through different paths (called modes).

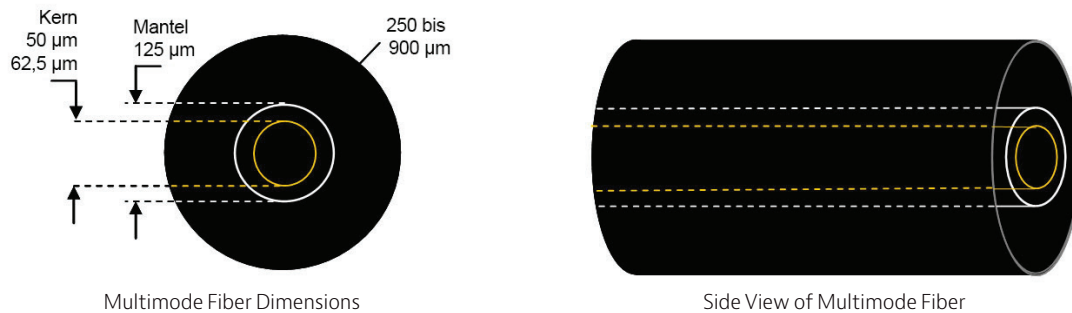

Launch Conditions

Launch conditions correspond to how optical power is launched into the fiber core when measuring fiber attenuation.

Ideal launch conditions should occur if the light is distributed through the whole fiber core. Actually, multimode optical fiber launch conditions may typically be characterized as being **underfilled or overfilled**.

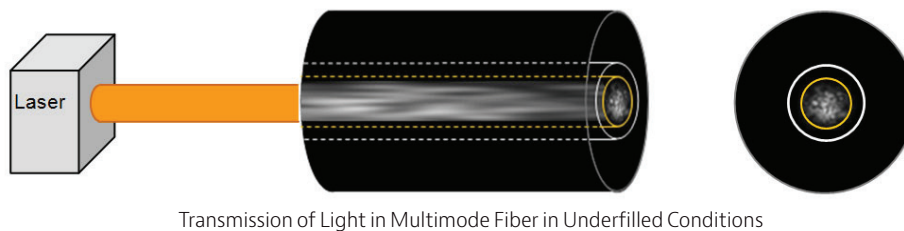

They are characterized as underfilled when most of the optical power is concentrated in the center of the fiber, which occurs when the launch spot size and angular distribution are smaller than the fiber core (for example, when the source is a laser or virtual cavity surface-emitting laser [VCSEL]).

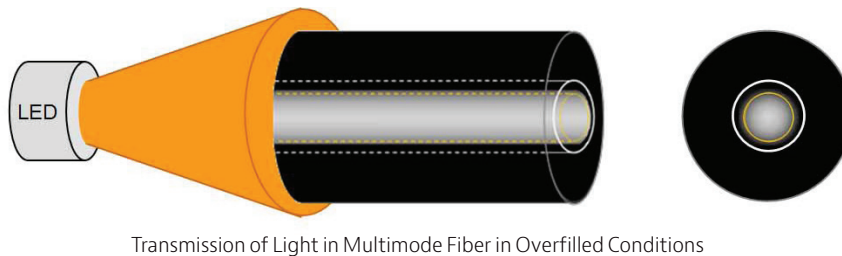

An overfilled launch condition occurs when the launch spot size and angular distribution are larger than the fiber core (for example, when the source is a light-emitting diode [LED]). Incident light that falls outside the fiber core is lost as well as light that is at angles greater than the angle of acceptance for the fiber core.

Light sources affect attenuation measurements such that one that underfills the fiber exhibits a lower attenuation value than the actual, whereas one that overfills the fiber exhibits a higher attenuation value than the actual.

Underfilled/Overfilled—Which is Best?

Neither underfilled or overfilled is optimal, because both result in measurement variations.

Measurement variations are not critical when the allowed loss budget is over-dimensioned versus the expected bandwidth. But it is important to know the variation range for loss budget when it is close to its limit. In that case, a 50-percent variation may be too important for certifying the network, thus requiring fine measurements.

The International Electrotechnical Commission (IEC) 61280-4-1 provides guidance to guarantee that attenuation variations remain within ± 10 percent.

Using IEC 61280-4-1-compliant test equipment in the field ensures that attenuation measurements will vary less than ± 10 percent for >1 dB loss and ± 0.07 dB for <1 dB loss among various test equipment.

Encircled Flux

The new parameter covered in the IEC 61280-4-1 Ed2 standard from June 2009 is known as Encircled Flux (EF), which is related to distribution of power in the fiber core and also the launch spot size (radius) and angular distribution.

EF corresponds to the ratio between the transmitted power at a given radius of the fiber core and the total injected power. For example, the picture below illustrates the transmitted power at a radius of 15 μm (light blue). The EF value at 15 μm equals the ratio between the amount of light transmitted in that middle part and the total amount of light emitted into the whole core (yellow circle):

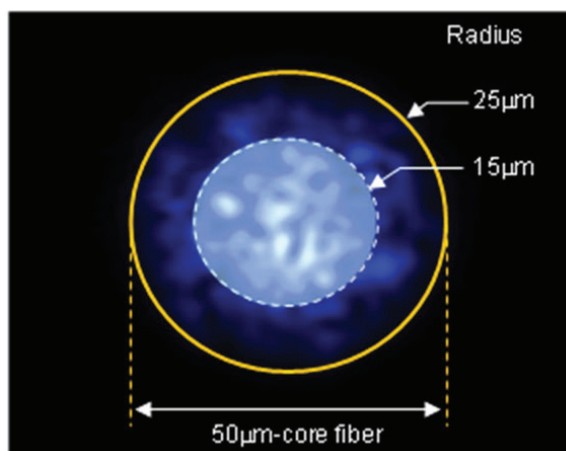
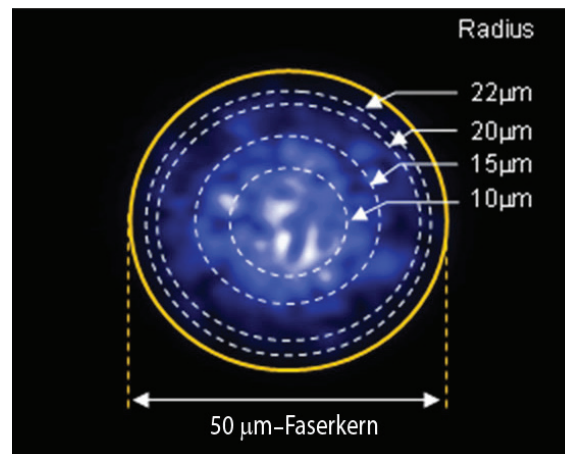

Illustration of EF value at 15 μm radius of a 50 μm -core fiber

IEC 61280-4-1 Standard

The IEC 61280-4-1 standard recommendations are based on the defined lower and upper boundaries of EF values at four predefined radii of the fiber core (10, 15, 20, and 22 μm), and for each wavelength (850 and 1300 nm).



Illuminated core of a 50 μm -core

Field Solution

IEC 61280-4-1 requires that the light coming from the end of the launching cord complies with the recommended EF boundaries.



Checking EF Compliance in the Field

Performing tests with IEC 61280-4-1 qualified equipment does not ensure that launch conditions comply with the standard at the time of testing, as variations can exist in the launching cord used or other variables.

Technicians conducting field measurements cannot access the EF measurement needed to check the launch conditions; therefore, the IEC 61280-4-1 standard proposes using physical artifacts.

Technical Solution—EF Modal Controller

EF-compliance is provided through the use of a modal controller device that is either integrated into the test equipment (light source or OTDR), or an external device. This device can be inserted either between the source and the fiber under test (LSPM¹ method), or between the OTDR and the launch cable (OTDR measurement). Some modal controllers may also include a launch cable for direct connection to the fiber under test during OTDR measurements.

The EF modal controller is a passive device that ensures that launch conditions meet the IEC 61280-4-1 requirements regardless of the light source used (LED or laser). Modal controllers exist for both 50 and 62.5 mm core fibers, some with integrated launch cables.



Example of a Modal Controller w/ Built-in Launch Cable

Non-EF-Compliant Devices

Launch Cable

Multimode launch cables allow for the signal to achieve modal equilibrium, but it does not ensure test equipment will be EF-compliant based on the IEC 61280-4-1 standard.

Multimode launch cables are used to reveal the insertion loss and reflectance of the near-end connection to the link under OTDR test. They also reduce the impact of possible fiber anomalies near the light source on the test.



Launch Cable

¹ Light Source / Power Meter Method

Fiber Mandrel

If the fiber is overfilled, high-order mode power loss can significantly affect measurement results. Fiber mandrels that act as “low-pass mode filters” can eliminate power in high-order modes. It effectively eliminates all loosely coupled modes that are generated by an overfilled light source while it passes tightly coupled modes on with little or no attenuation. This solution does not make test equipment EF-compliant.



Mandrel

Mode Conditioning Patch Cord

Mode conditioning patch cords reduce the impact of differential mode delay on transmission reliability in Gigabit Ethernet applications, such as 1000Base-LX. They also properly propagate the laser VCSEL light along a multimode fiber. This solution does not make test equipment EF-compliant.



Mode Conditioning Patch Cord

Impact of EF Modal Controller on Different Sources (LED and Laser)

Without control of the launch conditions (example below), the measurement of loss budget may vary significantly depending on the source used (LED or laser).

Using a modal controller to control the launch conditions according to the IEC standard (example below) can guarantee that the difference between LB1 and LB2 is less than 10 percent.

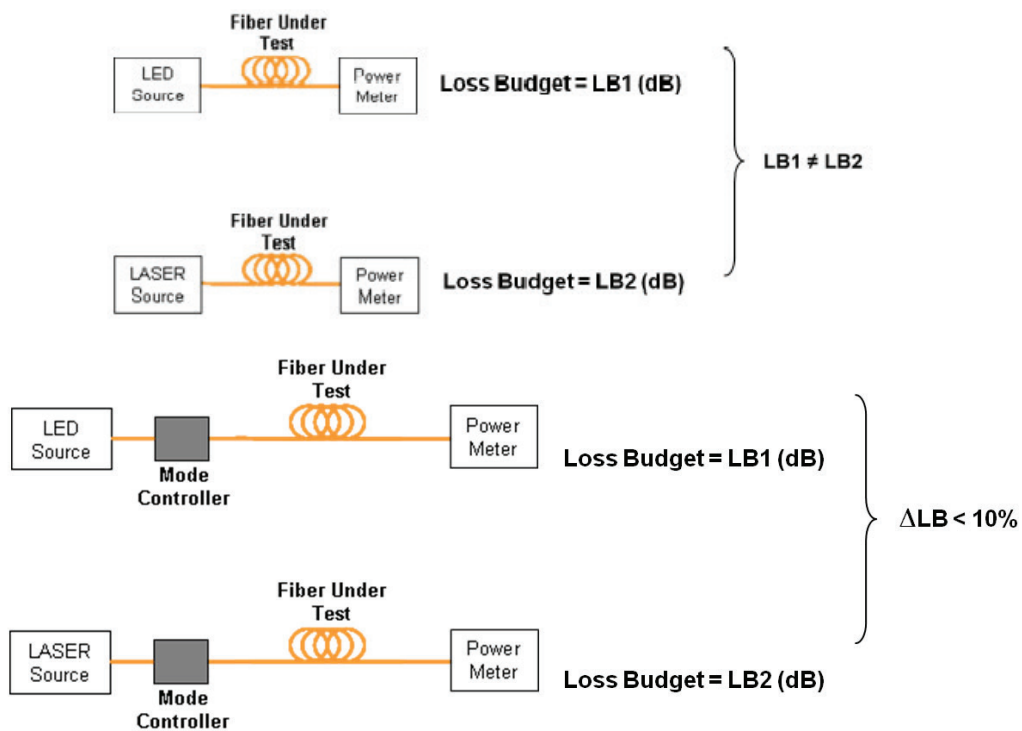

Viavi Solutions for Enterprise

Viavi offers a complete range of test tools for characterizing any type of multimode network according to the recent IEC 61280-4-1 standard.



Certifier40G Tier 1 Fiber Certifier



Viavi OLP-3x & OLS-34 SmartPocket™
Optical Power Meter & Light Source



EF Modal Controller for 50 μm Multimode Fiber



Contact Us **+1 844 GO VIAVI**
(+1 844 468 4284)

To reach the Viavi office nearest you,
visit viavisolutions.com/contacts.

© 2015 Viavi Solutions Inc.
Product specifications and descriptions in this
document are subject to change without notice.
mmfiberchar-an-fop-tm-ae
30162977 902 0412